

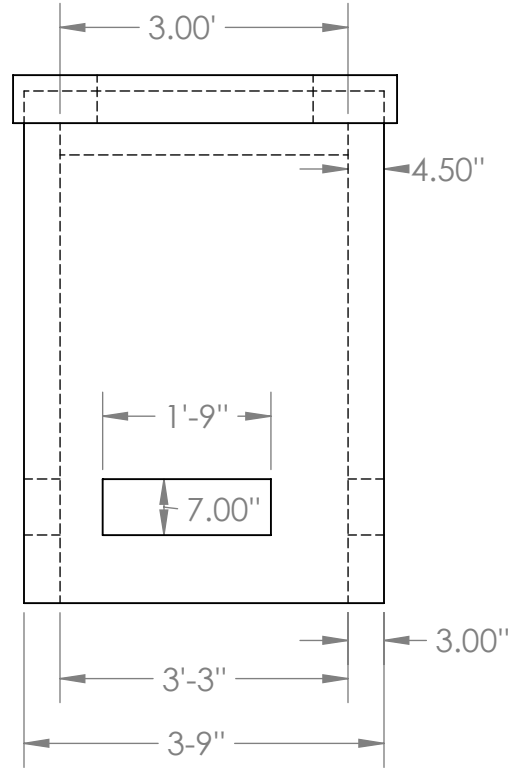

59 Shaw Rd Sanford Maine
 Telephone: 207-324-6125
 WWW.RPEPIN.COM
 A Division of R. Pepin & Sons, Inc

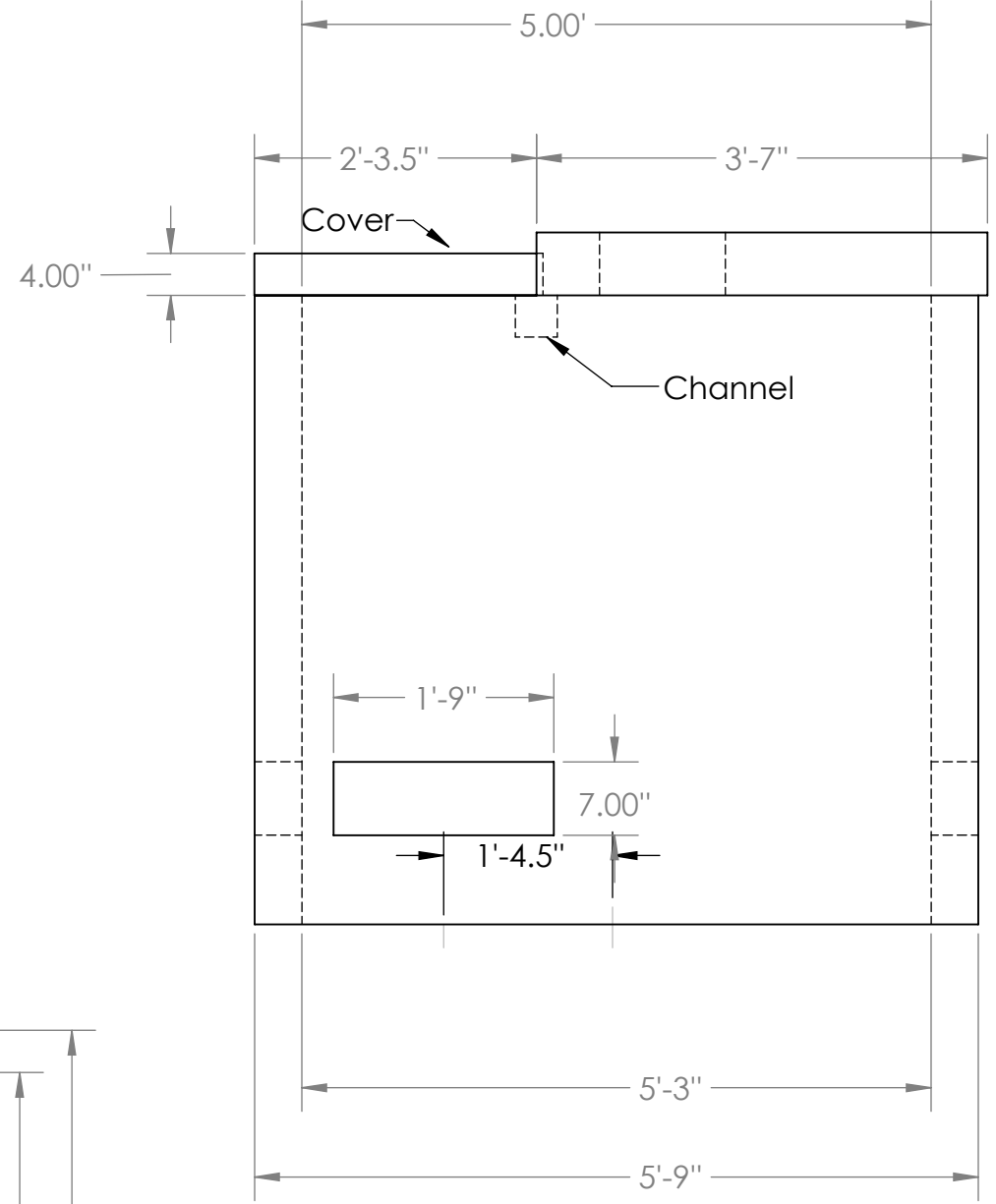

Side View



Front View

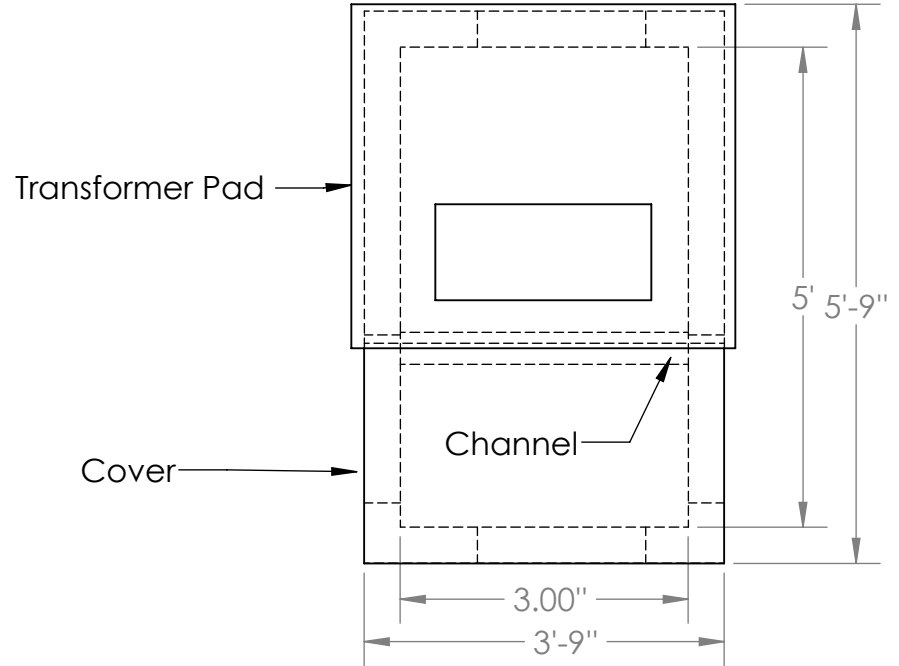

Top View

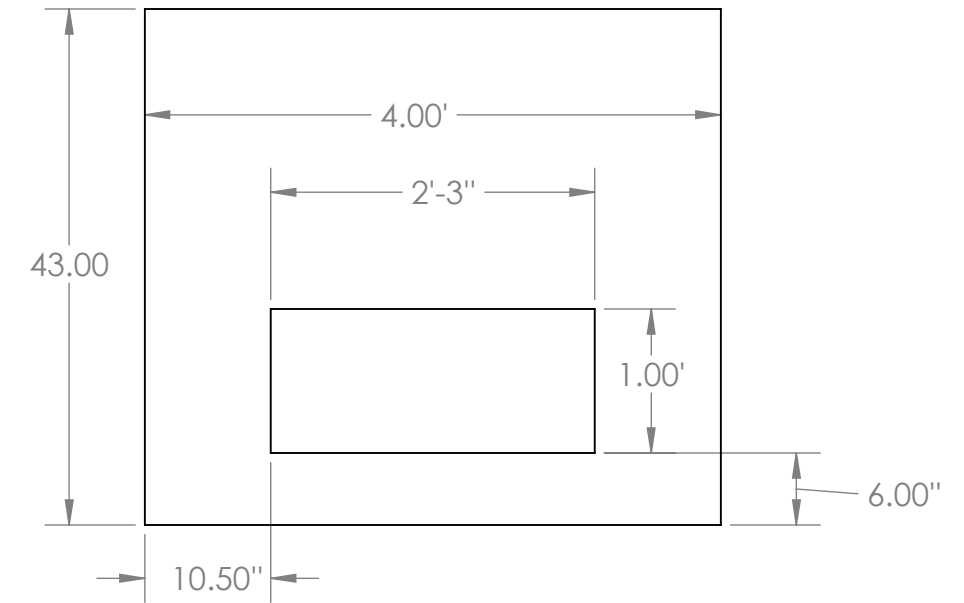

Transformer Pad

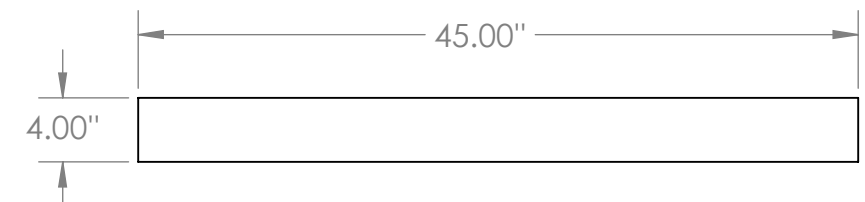

Cover

Specification

1. CONCRETE 5,000 PSI AFTER 28 DAYS
2. CEMENT PORTLAND TYPE II PER ASTM C150-81
3. STEEL REINFORCEMENT PER ASTM A-615. GRADE 60
4. DESIGN LOADING PER AASHTO HS-20
5. JOINTS SEALED WITH CONSEAL CS-102 BUTYL SEALAN